

# Directive Systems & Engineering

2702 Rodgers Terrace  
Haymarket, VA 20169-1628

[www.directivesystems.com](http://www.directivesystems.com)

703-754-3876

## 12cm Loop Yagi Kit, Model DSE1245LYK

### SPECIFICATIONS

Frequency range:	2.35 to 2.45 GHz	Gain:	20 dBi
Number of elements:	45	3 dB Beamwidth	
Boom length:	80 inches	(E plane):	16°
Boom diameter:	0.5" inches	F/B ratio:	≥20 dB
Mast diameter:	1 1/2 in. max	Maximum Power:	400 W average
Weight: (assembled)	3 pounds	Stacking distance:	13 inches' vertical
Connector:	Type-N female		15 inches' horizontal

### PARTS LIST

*Note: All hardware is Stainless Steel unless otherwise noted.*

Quantity	Description	Quantity	Description
2	0.5" Drilled boom	45	4-40 x 3/4" Machine screw
2	Reflector 1 & 2	45	4-40 Lock nut
1	Driven element	2	8-32 x 1/2" Machine screw
12	Directors 1-12	2	8-32 x 1" Machine screw
5	Directors 13-17	4	8-32 Hex Nut
6	Directors 18-23	4	8-32 Split lock washer
12	Directors 24-35	1	Boom-to-mast "L" bracket
7	Directors 36-42	1	Boom-to-mast plate
1	Anti-Seize Compound	1	U-bolt with nuts & lock washers
2	1/2" Black End Cap	1	Saddle
		1	Cable assy w/connector
		1	Assembly Manual

**Anti-Seize Compound** - Apply a small amount of the supplied Anti-Seize Compound to the aluminum joints and to the threads of the U-Bolts to prevent galling.

**BEFORE INSTALLING YOUR NEW ANTENNA, PLEASE BE SURE TO READ THE ENCLOSED WARNING PAMPHLET.**

**CAUTION:** *While we strive to remove all burrs from all machined parts, there is always the possibility of sharp edges. We strongly suggest checking the edges and use a fine file, or 400 grit sandpaper, to remove any burrs that may have been left.*



*(Can be up or down)*

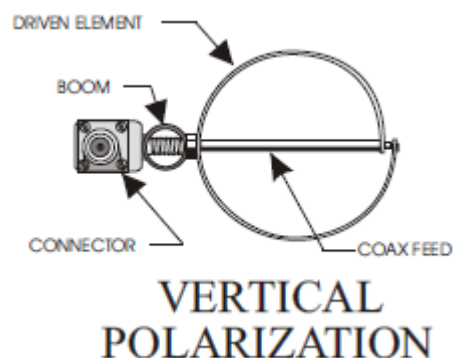

*(Can be left or right)*

### **ASSEMBLY INSTRUCTIONS**

- 1) Unpack the antenna and locate the hardware package. Antenna booms are shipped in two sections. Use the alignment marks on the boom to correctly connect the boom pieces.
- 2) Attach loops to the boom with 4-40 x 3/4" screws, lock washers and nuts in proper sequence. Loops go on the side of the boom marked with an "X". Attach the contents of each bag of elements before opening the next bag. This will prevent any mix-up of elements on the boom. When tightening the nuts on the parasitic elements, be careful not to torque them too tightly. Snug down the nuts, align the elements and use a screwdriver for the final tightening. A 1/4" nut driver is almost mandatory for this job! Attach the driven element with the 1/4-20 stainless steel nut. If only a single antenna is being built, it doesn't matter which way the loop is oriented. If antennas are to be stacked, see "Instructions for Stacking Loop Yagis".
- 3) Attach the boom-to-mast angle bracket and 8-32 x 1" hardware on the boom.
- 4) Attach the boom-to-mast plate to the angle bracket with the 8-32 x 1/2" screws, lock washers and nuts. Install U-bolt so that the mast is directly under the boom.
- 5) Install the cable assembly through the hole in the driven element mounting bolt. Make sure the connector bracket is correctly oriented, the bend should be forward for center mount antennas and rear facing for rear mount antennas. Solder the outer shield to the driven loop first making sure there is no shield sticking above the large hole in the driven loop. After the shield is soldered, pass the center conductor through the small hole in the driven loop and bend the center conductor over and solder (See Assembly Tips below).

*We have created a You Tube video, the link of which can be found on our website, documenting the following steps:*

<https://youtu.be/ojXbsDv5cvU>

At this point the connector assembly is facing down, connect a piece of coax and your SWR bridge or VNA. Pull down on the connector (which will flatten the loop) until you reach the lowest SWR. If it's less than 1.5:1 you can stop and make sure the loop doesn't try to pop back up, sometimes you have to squeeze the loop with your fingers to make sure it stays in the shape that gave the best SWR. If you want to further lower the SWR, from the rear of the

antenna, place both your thumbs on the driven loop on either side and gently push it forward towards D1, you only need to tilt it maybe  $\frac{3}{16}$ " to  $\frac{1}{4}$ " and that should drop the SWR to 1.1:1 or less.

Now, GENTLY bend the UT-141 coax after it exits the boom towards the front or rear, depending on the mounting. You do not want to bend it so tightly that it crushes where it extends through the bolt. The connector bracket should line up with either D1 or D2 (or the hole with the circle around it on rear mount antennas), remove that nut and place the connector bracket on the screw and re-attach the nut. If the bracket doesn't line up, sometimes you have to flip the bracket. Loosen the  $\frac{3}{4}$ " nut by holding the connector body with a  $\frac{9}{16}$ " open end wrench. Remove the connector bracket and flip it.



Connector doesn't fit



Front Mount Connector



Rear Mount Connector

- 6) Attach the feedline and tape it to the mast. Seal all connections with silicone RTV or equivalent.
- 7) Attach the two black end caps, and this will complete the assembly of your DSE1345LYK.
- 8) The SWR should be 1.5:1 or better. Additional tweaking can be accomplished by adjusting the distance between the driven element and R1 or by adjusting the shape of the driven element.

**DO NOT, UNDER ANY CIRCUMSTANCES, APPLY ANY TYPE OF SEALANT OR COATING TO THE DRIVEN ELEMENT, T-ARMS OR CONNECTOR ASSEMBLY, OTHER THAN KRYLON® CLEAR COAT. ANY OTHER COATING WILL ADVERSELY AFFECT THE SWR AND VOID YOUR WARRANTY.**

## ASSEMBLY TIPS:

The boom diameter is 0.5 inch, and it is drilled for 4-40 hardware (no. 33 drill bit). The driven element hole is enlarged to 1/4 inch. All elements are 0.032-inch-thick and 0.250 inch wide. Note that the element spacing from D7 on is 2.0025 inches. To bend elements, wrap the strip around a suitable form (such as a piece of pipe or tubing). The driven element is formed in the same way then soldered to the mounting bolt as shown. The feed coaxial cable (0.141-inch semi rigid) goes through the mounting bolt and is soldered to the open ends of the element. For best match, the driven element should be approximately 1.375 inches high; this makes it wider than it is tall. This shape can be adjusted for best match. This antenna is based on work done by G3JVL.

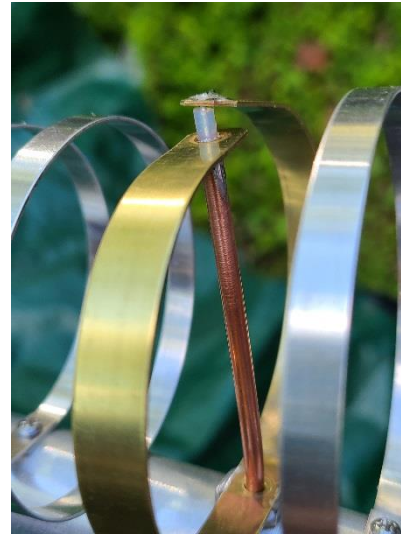
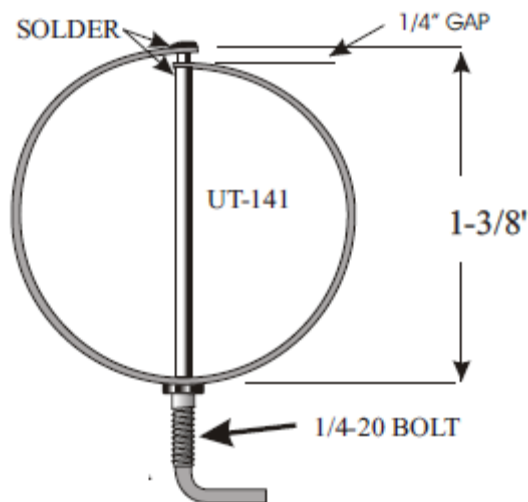

Soldered Driven Element

## Directive Systems Warranty Policy

All Directive Systems antennas are built with the finest materials available. We take great pride in building a quality product that will give years of good service and performance. . If there is a defect in materials or workmanship within 90 days of purchase, Directive Systems will repair or replace the defective part, free of charge, to the original purchaser. **DO NOT RETURN ANYTHING WITHOUT PRIOR AUTHORIZATION FROM DIRECTIVE SYSTEMS.** Please contact us either by phone or email describing the problem and we will work to resolve it.

If, after examining a new antenna you received, you are not satisfied, contact us immediately for return authorization and refund. **ANY ANTENNA THAT HAS BEEN MODIFIED WILL BE SUBJECT TO A RESTOCKING CHARGE. IF AN ANTENNA IS SO MODIFIED AS TO MAKE IT UNUSABLE, DIRECTIVE SYSTEMS RESERVES THE RIGHT TO REFUSE TO ACCEPT THE ANTENNA FOR RETURN.**

### DIMENSIONS OF 2401 MHz LOOP YAGI, MODEL 1245LY(K)

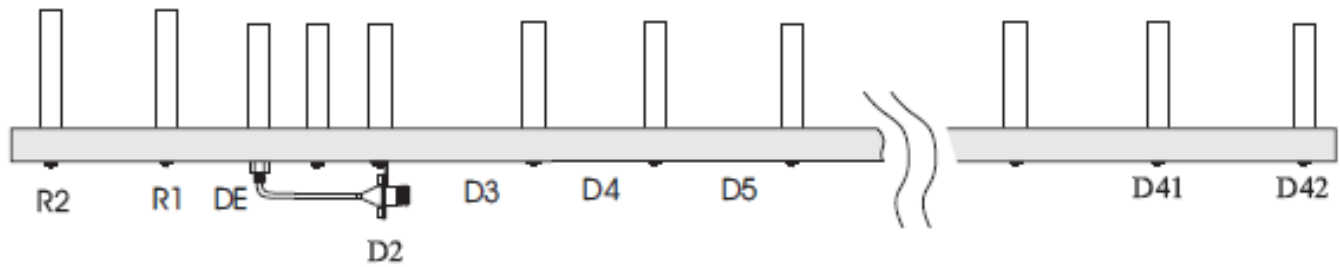

<i>Element</i>	<i>Spacing from end of boom</i>	<i>Circumference</i>	<i>Element</i>	<i>Spacing from end of boom</i>	<i>Circumference</i>	<i>Element</i>	<i>Spacing from end of boom</i>	<i>Circumference</i>
R2	0.500	5.259	D13	21.898	4.351	D28	51.935	4.160
R1	2.244	5.259	D14	23.900	4.351	D29	53.938	4.160
DE	2.728	4.918	D15	25.903	4.351	D30	55.940	4.160
D1	3.408	4.487	D16	27.905	4.215	D31	57.943	4.160
D2	3.875	4.487	D17	29.908	4.215	D32	59.945	4.160
D3	4.876	4.487	D18	31.910	4.215	D33	61.948	4.160
D4	5.878	4.487	D19	33.913	4.215	D34	63.950	4.160
D5	6.581	4.487	D20	35.915	4.215	D35	65.953	4.160
D6	7.880	4.487	D21	37.918	4.215	D36	67.955	4.106
D7	9.883	4.487	D22	39.920	4.160	D37	69.958	4.106
D8	11.885	4.487	D23	41.923	4.160	D38	71.960	4.106
D9	13.888	4.487	D24	43.925	4.160	D39	73.963	4.106
D10	15.890	4.487	D25	45.928	4.160	D40	75.965	4.106
D11	17.893	4.487	D26	47.930	4.160	D41	77.968	4.106
D12	19.895	4.487	D27	49.933	4.160	D42	79.970	4.106

Note: All dimensions are in inches