

# Directive Systems & Engineering

2702 Rodgers Terrace

Haymarket, VA 20169-1628

[www.directivesystems.com](http://www.directivesystems.com)

703-754-3876

## 9cm Loop Yagi Kit (Rear Mount), Model DSE945LYRMK

### SPECIFICATIONS

Frequency range:	3.4 to 3.5 GHz	Gain:	20 dBi
Number of elements:	45	3 dB Beamwidth	
Boom length:	60 inches	(E plane):	16°
Boom diameter:	0.5 inch	F/B ratio:	≥20 dB
Mast diameter:	1 1/2 inches max	Maximum Power:	100 W average
Weight: (assembled)	1.5 pounds	Stacking distance:	9 inches' vertical
Connector:	Type-N female		9.8 inches' horizontal

### PARTS LIST

*Note: All hardware is Stainless Steel unless otherwise noted.*

Quantity	Description	Quantity	Description
1	0.5" x 48" drilled boom	44	3-48 x 3/4" machine screw
1	0.5" x 36" drilled boom	44	3-48 x 3/4" split lock washer
2	reflectors 1&2	44	3-48 x hex nut
1	driven element	2	8-32 x 1/2" machine screw
11	directors 1-11	2	8-32 x 1" machine screw
7	directors 12-18	4	#8 split lock washer
6	directors 19-24	4	#8 hex nut
12	directors 25-36	1	boom to mast angle bracket
6	directors 37-42	1	boom to mast plate
2	1/2" black end caps	1	U-bolt with nuts & saddle
1	Anti-Seize Compound	1	Cable assembly w/connector
		1	Assembly manual

**Anti-Seize Compound** - Apply a small amount of the supplied Anti-Seize Compound to the aluminum joints and to the threads of the U-Bolts to prevent galling.

**BEFORE INSTALLING YOUR NEW ANTENNA, PLEASE BE SURE TO READ THE ENCLOSED WARNING PAMPHLET.**

**CAUTION:** *While we strive to remove all burrs from all machined parts, there is always the possibility of sharp edges. We strongly suggest checking the edges and use a fine file, or 400 grit sandpaper, to remove any burrs that may have been left.*

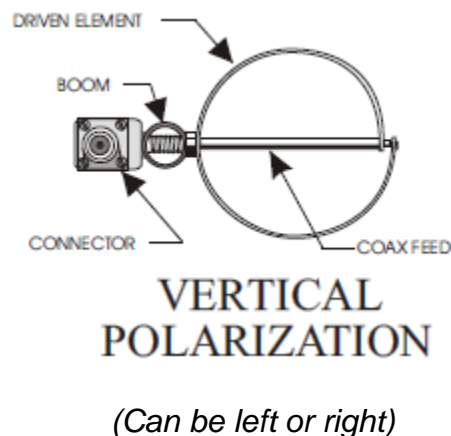

### ASSEMBLY INSTRUCTIONS

- 1) Assemble the boom, the splice is between elements D24 & D25 and is secured by the loop mounting screws of D22, 23 & 24. Attach loops to the boom with 3-48 x 3/4" screws, lock washers and nuts in proper sequence. Loops go on the side of the boom marked with an "X". Attach the contents of each bag of elements before opening the next bag. This will prevent any mix-up of elements on the boom. When tightening the nuts on the parasitic elements, be careful not to torque them too tightly. Snug down the nuts, align the elements and use a screwdriver for the final tightening. A 3/16" nut driver is almost mandatory for this job! Attach the driven element with the 5/16" nut. If only a single antenna is being built, it does not matter which way the loop is oriented. If antennas are to be stacked, see "Instructions for Stacking Loop Yagis."
- 2) Attach the boom-to-mast bracket with the angle bracket and 8-32 X 1" hardware. Use the two large holes on the rear boom piece. Install the 3" X 4" flat plate with 8-32 X 1/2" hardware provided. Install U-bolt on the flat plate so that the mast is directly under the boom.
- 3) Install the cable assembly through the hole in the driven element mounting bolt. Make sure the connector bracket is correctly oriented, the bend should be forward for center mount antennas and rear facing for rear mount antennas. Solder the outer shield to the driven loop first making sure there is no shield sticking above the large hole in the driven loop. After the shield is soldered, pass the center conductor through the small hole in the driven loop and bend the center conductor over and solder (See Assembly Tips below).

*We have created a You Tube video, the link of which can be found on our website, documenting the following steps:*

<https://youtu.be/ojXbsDv5cvU>

At this point the connector assembly is facing down, connect a piece of coax and your SWR bridge or VNA. Pull down on the connector (which will flatten the loop) until you reach the lowest SWR. If it's less than 1.5:1 you can stop and make sure the loop doesn't try to pop back up, sometimes you have to squeeze the loop with your fingers to make sure it stays in

the shape that gave the best SWR. If you want to further lower the SWR, from the rear of the antenna, place both your thumbs on the driven loop on either side and gently push it forward towards D1, you only need to tilt it maybe 3/16" to 1/4" and that should drop the SWR to 1.1:1 or less.

Now, GENTLY bend the UT-141 coax after it exits the boom towards the front or rear, depending on the mounting. You do not want to bend it so tightly that it crushes where it extends through the bolt. The connector bracket should line up with either D1 or D2 (or the hole with the circle around it on rear mount antennas), remove that nut and place the connector bracket on the screw and re-attach the nut. If the bracket doesn't line up, sometimes you have to flip the bracket. Loosen the 3/4" nut by holding the connector body with a 9/16" open end wrench. Remove the connector bracket and flip it.



Connector doesn't fit



Front Mount Connector



Rear Mount Connector

- 4) Attach the feed line and tape it to the mast. Seal all connections with silicone RTV or equivalent.
- 5) Attach the two black end caps and this will complete the assembly of your DSE945LYRMK.
- 6) The SWR should be 1.5:1 or better. Additional tweaking can be accomplished by adjusting the distance between the driven element and R1 or by adjusting the shape of the driven element.

### ASSEMBLY TIPS:

The boom diameter is 0.50 inch, and it is drilled for 3-48 hardware (no. 34 drill bit). The driven element hole is 1/4-inch dia. All elements are 0.020-inch-thick and 0.200 inch wide. Note that the element spacing from D7 on is 1.335 inches. The driven element is installed in the 1/4" hole in the boom. The feed coaxial cable (0.141-inch semi rigid) goes through the mounting bolt and is formed in a 90-degree bend so that the connector bracket can be bolted to the boom at reflector #2 using the R2 hardware. The end opposite the connector is soldered to the open ends of the brass element. Allow a 3/16" max gap at the feed point. For best match, the driven element should be approximately 7/8 inches high; this makes it wider than it is tall.

This shape can be adjusted for best match. After final tune-up, it is a good idea to solder the UT-141 to the brass bolt at the bolt head. Use a large 150-watt+ soldering iron. This antenna is based on work done by G3JVL.

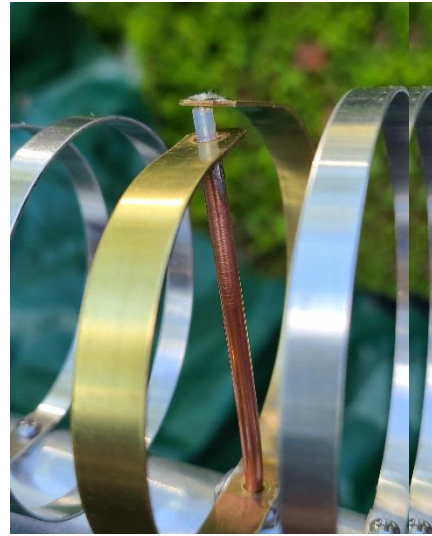
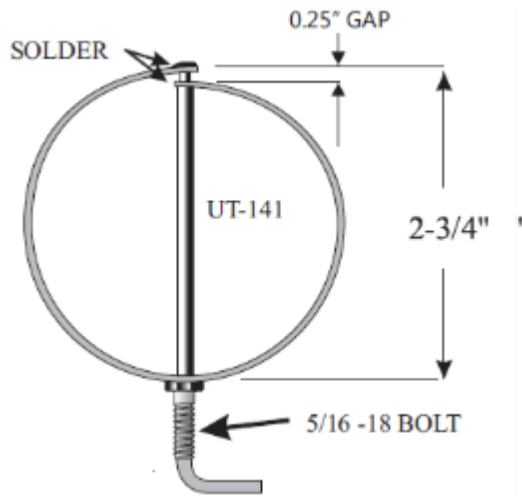

Soldered Driven Element

### DIMENSIONS OF 3456 MHz LOOP YAGI, MODEL 945LY(K)

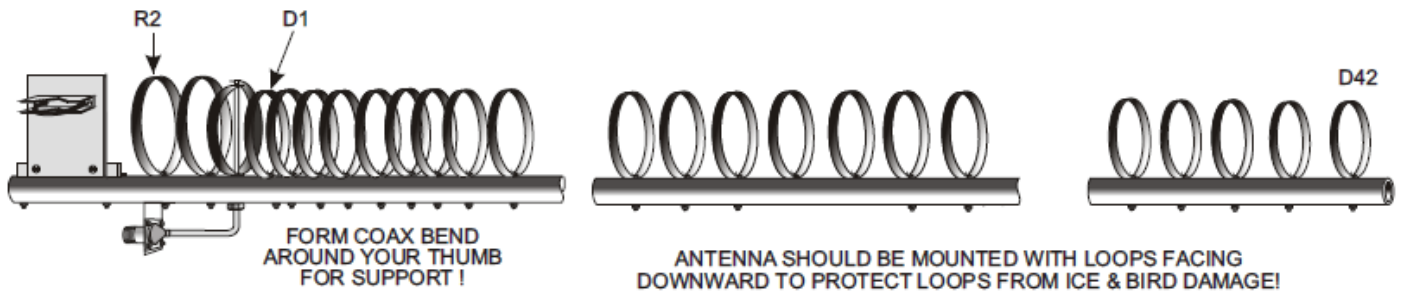

<i>Element</i>	<i>Spacing from end of boom</i>	<i>Circumference</i>	<i>Element</i>	<i>Spacing from end of boom</i>	<i>Circumference</i>	<i>Element</i>	<i>Spacing from end of boom</i>	<i>Circumference</i>
R2	6.000	3.741	D13	20.265	3.095	D28	40.290	2.966
R1	7.050	3.741	D14	21.599	3.095	D29	41.625	2.966
DE	7.518	3.570	D15	22.935	3.095	D30	42.960	2.966
D1	7.938	3.192	D16	24.269	3.095	D31	44.295	2.966
D2	8.250	3.192	D17	25.605	3.095	D32	45.630	2.966
D3	8.917	3.192	D18	26.940	3.095	D33	46.965	2.966
D4	9.584	3.192	D19	28.275	3.000	D34	48.300	2.966
D5	10.053	3.192	D20	29.610	3.000	D35	49.635	2.966
D6	10.920	3.192	D21	30.945	3.000	D36	50.970	2.966
D7	12.255	3.192	D22	32.280	3.000	D37	52.305	2.940
D8	13.590	3.192	D23	33.615	3.000	D38	53.640	2.940
D9	14.925	3.192	D24	34.950	3.000	D39	54.975	2.940
D10	16.260	3.192	D25	36.285	2.966	D40	56.310	2.940
D11	17.595	3.192	D26	37.620	2.966	D41	57.645	2.940
D12	18.930	3.095	D27	38.955	2.966	D42	58.980	2.940

Note: All dimensions are in inches.

DO NOT, UNDER ANY CIRCUMSTANCES, APPLY ANY TYPE OF SEALANT OR COATING TO THE DRIVEN ELEMENT, T-ARMS OR CONNECTOR ASSEMBLY, OTHER THAN KRYLON® CLEAR COAT. ANY OTHER COATING WILL ADVERSELY AFFECT THE SWR AND VOID YOUR WARRANTY.

### Directive Systems Warranty Policy

All Directive Systems antennas are built with the finest materials available. We take great pride in building a quality product that will give years of good service and performance. If there is a defect in materials or workmanship within 90 days of purchase, Directive Systems will repair or replace the defective part, free of charge, to the original purchaser. **DO NOT RETURN ANYTHING WITHOUT PRIOR AUTHORIZATION FROM DIRECTIVE SYSTEMS.** Please contact us either by phone or email describing the problem and we will work to resolve it.

If, after examining a new antenna you received, you are not satisfied, contact us immediately for return authorization and refund. **ANY ANTENNA THAT HAS BEEN MODIFIED WILL BE SUBJECT TO A RESTOCKING CHARGE. IF AN ANTENNA IS SO MODIFIED AS TO MAKE IT UNUSABLE, DIRECTIVE SYSTEMS RESERVES THE RIGHT TO REFUSE TO ACCEPT THE ANTENNA FOR RETURN.**