

Directive Systems & Engineering

2702 Rodgers Terrace
Haymarket, VA 20169-1628

www.directivesystems.com

703-754-3876

25 Element 7.4 wl. K1FO Designed Yagi, Model DSEFO432-25ATV

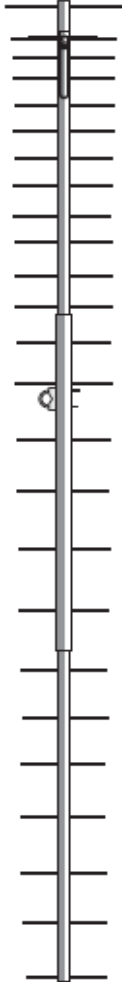

ELECTRICAL SPECIFICATIONS

Frequency range: MHz	422-440
Gain: dBd.....	16.2-16.5
Impedance: Ohms.....	50
Connector type.....	Type N(F) UG-58/U
Front -to- back ratio: dB.....	24
SWR: Typical at resonance.....	≅1.2:1
Beamwidth: degrees	
E- Plane	22°
H- Plane	23°
Sidelobe level: decibels	
E- Plane	-17
H- Plane	-16
Power rating, Continuous: Watts	750
Stacking Distance: ft.(m)	
E- Plane.....	5'10" (1.778m)
H- Plane.....	5'6" (1.676m)

MECHANICAL SPECIFICATIONS

Boom length: in. (m.).....	17'3" (5.26)
Turning radius: in. (m.).....	9'6" (2.90)
Weight Assembled: Lbs (kg.).....	8.5 (3.86)
Max mast size: in. (cm.).....	2 (5.08)
Wind surface area: Ft (m.)	1.4 (.13)
Wind Survival: Mph (km/hr).....	100 (160)

PARTS LIST

Boom			
1 1/4" OD x 0.058 x 72" rear boom	1	Element Insulator	52
w. coax/ balun assy. attached		Keepers, s.s. 3/16"	56
1 3/8" OD x 0.058 x 70" center boom	1	Flat washer, s.s. 1/4"	4
1 1/4" OD x 0.058 x 72" front boom	1	Flat washer, s.s. 5/16"	4
Element bundle		U-bolt , s.s. 5/16-18 x 2"	2
25 elements w. 2 T-match rods	1	U-bolt, s.s. 1/4-20 x 1 1/2"	2
HARDWARE BAG		Nut, hex, s.s. 1/4-20	4
Hose clamps, stainless steel	2	Nut, hex, s.s. 5/16-18	4
8-32 x 1 3/4" machine screw	2	Lock washer, split, s.s. 5/16"	4
8-32 s.s. hex nut	2	Lock washer, split, s.s. 1/4"	4
#8 split s.s. lock washer	2	Boom to Mast plate	1
Brass T match bars	2	Assembly instructions	1
		Keeper Installation tool	1

CAUTION: *While we strive to remove all burrs from all machined parts, there is always the possibility of sharp edges. We strongly suggest checking the edges and use a fine file, or 400 grit sandpaper, to remove any burrs that may have been left.*

*Tools needed: ¼" flat blade screwdriver or 5/16" nut driver
soldering gun or large iron
rosin core solder
large needle nosed pliers
keeper installation tool (supplied with kit)
ruler with metric millimeter markings
marking pencil*

ASSEMBLY INSTRUCTIONS

- 1) The antenna components should be removed carefully from the shipping container and the individual parts counted and checked for completeness. Be careful to check all tubing pieces for elements and hardware that may be packed inside.
- 2) The boom consists of three aluminum tubing sections. The rear boom section already has the balun & driven element connector attached and is a 1 1/4" diameter tube 72" long. The mid boom is 1 3/8" diameter and 70" long and the front boom section is 1 ¼" diameter and 72" long. Assemble the three boom pieces and fasten with the 8-32 x 1 3/4" machine screws, hardware & s.s. worm clamps supplied. Align each boom section to the alignment marks.
- 3) The element bundle contains all of the elements needed for assembly. Take time to inventory and check off each dimension with Table 1. Some elements vary by one millimeter, so extreme care in measuring is required here. Arrange elements in order of descending size and mark each element with a scribe, or sharp tool to properly locate the first keeper position. The scribe dimensions are listed in Table 1 as the "Keeper half length". The keepers are the stainless steel fasteners that slide over the 3/16" dia. Aluminum elements. Note that the reflector element is the longest followed by the brass driven element, and then director #1. Director #23 is the shortest element. Once you have marked each element, and using the hollow assembly tool, push the keeper onto the element until it almost meets the scribed line. See the figure 6 for proper keeper orientation prior to attaching the keepers. Be careful as the keeper cannot reverse direction if you overshoot the line. You must push the keeper all the way to the end and start over. A good trick is to install the element in a bench vise (if available) with the scribed line flush with the edge of the vise jaws. Push the keeper until it is against the edge of the jaws. This way, it is impossible to overshoot the scribed line. Be aware that the keepers are designed to go a certain way. Now attach one keeper to every element as advised in Table 1 and shown below.

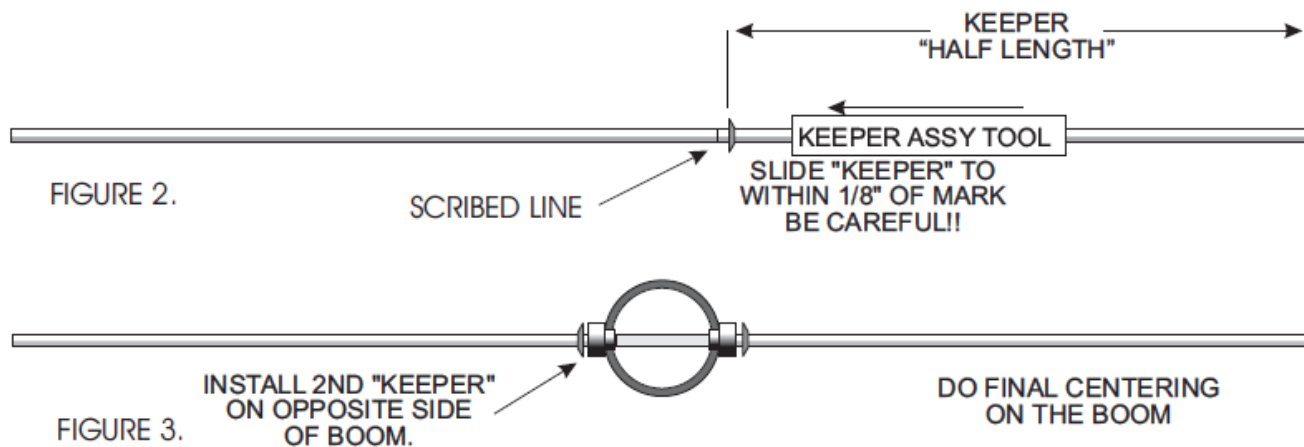

4) You are now ready to install the elements on the boom. Start at the rear of the antenna and install a pair of black insulators in the large 5/16" hole on each side of the boom. The insulators snap into the boom and are held in place with small "fingers". To "set" the fingers, insert an element about 1/2" into the insulator, it may require a bit of force until the fingers lock into place. Now slide the correct element (Refl) through the two insulators. Press a second keeper onto the opposite end of the element from the first keeper and push until the element is snugly captured on the insulator. Check that the element is centered on the boom. Equal lengths should extend on either side of the boom. Proceed with each succeeding element until all 25 elements are attached to the boom as shown above. Note that the driven element is brass rod, but is installed the same as the other elements.

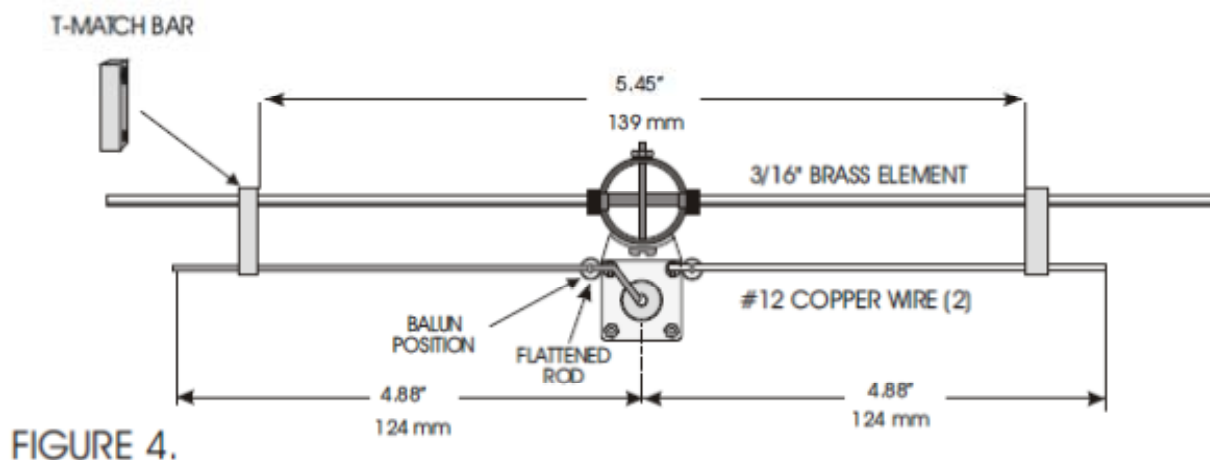

5) The driven element T-match assembly is constructed as shown in Figures 4 & 5. Locate the two brass T-arms. Both are preformed. One is straight with a flattened end, while the other is bent and flattened on one end. Locate also the two brass T-match bars and position them on the brass driven element as shown in Figure 4.

Install the two T-match rods and T-match bars on the driven element as shown in the diagram (Figure 4) above. Note that the formed end of the bent T-match rod is inserted into the solder cup of the Type N connector and routed through the pre-assembled standoff insulator. Solder the copper wires to the connector center pin and the two standoffs.

If you are installing multiple antennas, please be sure that you build each antenna with the same T-match wire orientation. In the above drawing, the center pin goes to the right hand side of the antenna as viewed from the back of the connector. Make sure both antennas do the same! Proper phase relationship is very important here!

6) Align the T-match bars parallel with the edge of the connector bracket, and adjust their position as shown in Figure 4 and 5. You can slide the bars carefully into position. Be careful and do not apply excessive force to the blue standoff insulators. They are easily broken with rough handling. You may have to bend the connector bracket slightly to achieve the listed dimensions in Figure 5.

7) Carefully bend the balun center conductor leads around the T match rods at the blue standoffs, as shown in Figure 5, and solder them both. The DSEFO432-25ATV covers a wide range, but can be adjusted to favor either end of the band depending on ATV activity in your area. Adjust the T Match length to the dimensions shown in Figure 4 for best performance at 439 MHz. For best results near 422 MHz leave the T match rods set at 5 1/8" and adjust the T match bars to 6 3/4" overall dimension between the bars. The T match bars may be adjusted for best match at your specific frequency, if you have good VSWR measuring equipment. See also our website (www.directivesystems.com/TMATCH.htm) for T match adjusting techniques. The settings in Figure 4 are for optimum performance at the high end of the ATV band. Curves for both settings are published on our website, and are worth viewing. Gain variation across the band is minimal.

Once the T-Match rods and brass bars are set, you can solder the T-Match bars as well. Soldering is best accomplished with a 40 watt iron or larger. The brass driven element absorbs considerable heat. This will complete the assembly of your DSEFO432-25ATV.

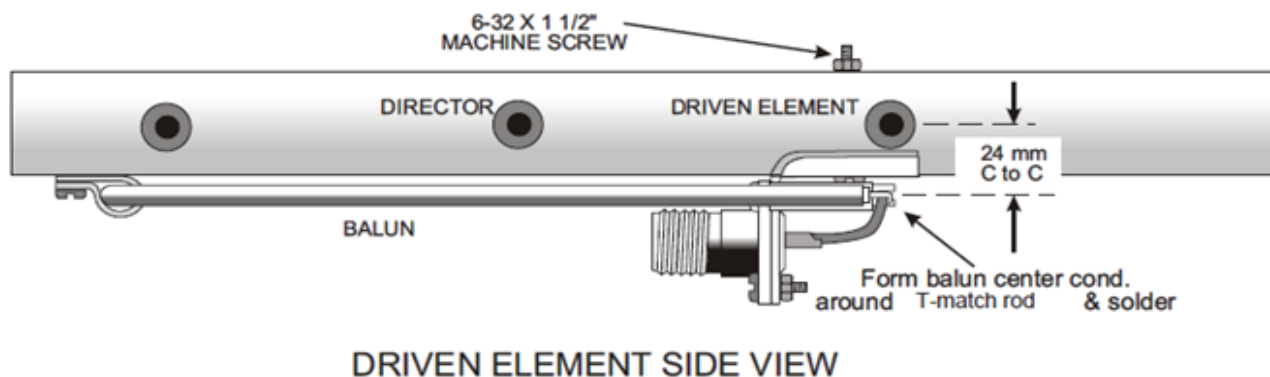

FIGURE 5.

8) You are now ready to install your antenna. Install the boom to mast bracket between Directors 12 & 13. The small 1 3/8" u-bolts connect the Yagi boom to the mast bracket. The large u-bolts attach the bracket to your support mast. Once you have the U-bolts installed and the antenna mounted on your support mast and tightened, you can route your feedline along the mast and over to the driven element and connector. Dress the coax against the antenna boom and tighten the connector. Seal the connector body with several layers of good grade vinyl tape. Then apply a layer of butyl rubber antenna sealer or RTV over the tape. This will provide a good vapor barrier and ensure years of trouble free performance. It is also a good idea to spray the driven element with a clear spray such as Rustoleum Clearseal or Krylon

clear spray. Be sure to cover the connector before spraying. This will enhance the vapor barrier, preventing any water vapor from entering the connector, and prevent oxidation of the brass components. This insulated element design will provide very long service life in harsh environments with no degradation over many years.

TABLE 1

<i>Element Description</i>	<i>Element Length mm. +/- 1mm</i>	<i>Keeper Half Length mm.</i>
Reflector	339	152
Driven Element	333	148
Director #1	316	140
Director #2	305	135
Director #3	299	132
Director #4	295	130
Director #5	291	128
Director #6	289	127
Director #7	287	126
Director #8	285	125.5
Director #9	283	124.5
Director #10	281	124
Director #11	280	121
Director #12	279	120.5
Director #13	278	120
Director #14	277	120
Director #15	276	119.5
Director #16	275	119
Director #17	273	119
Director #18	272	119
Director #19	271	118.5
Director #20	270	118
Director #21	269	117.5
Director #22	268	117
Director #23	267	116.5

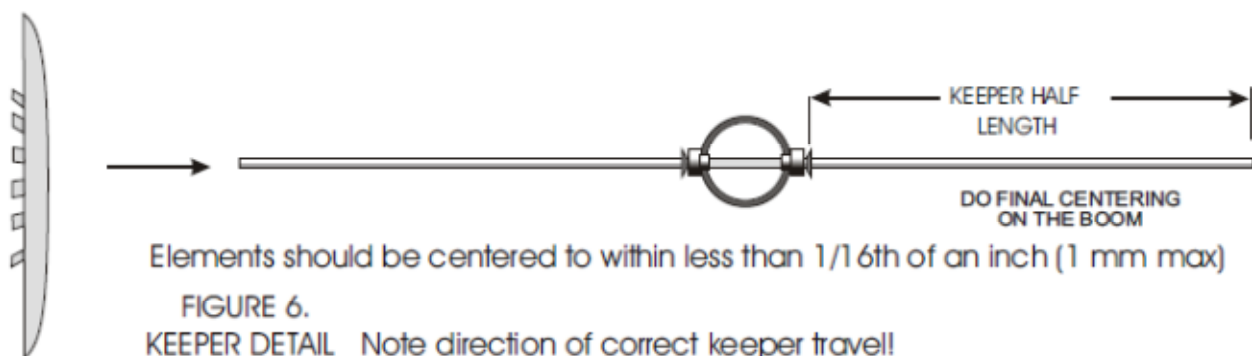

Directive Systems Warranty Policy

All Directive Systems antennas are built with the finest materials available. We take great pride in building a quality product that will give years of good service and performance. If there is a defect in materials or workmanship within 90 days of purchase, Directive Systems will repair or replace, free of charge, the defective part. **DO NOT RETURN ANYTHING WITHOUT PRIOR AUTHORIZATION FROM DIRECTIVE SYSTEMS.**

Please contact us either by phone or email describing the problem and we will work to resolve it.

If, after examining a new antenna you received, you are not satisfied, contact us immediately for return

authorization and refund. **ANY ANTENNA THAT HAS BEEN MODIFIED WILL BE SUBJECT TO A RESTOCKING CHARGE. IF AN ANTENNA IS SO MODIFIED AS TO MAKE IT UNUSABLE, DIRECTIVE SYSTEMS RESERVES THE RIGHT TO REFUSE TO ACCEPT THE ANTENNA FOR RETURN.**