

Directive Systems & Engineering

2702 Rodgers Terrace
Haymarket, VA 20169-1628

www.directivesystems.com

703-754-3876

33cm Loop Yagi (Rear Mount), Model DSE3318LYARMK

SPECIFICATIONS

Frequency Range:	910-930 MHz
Number of elements:	18
Boom Length:	72 inches
Boom diameter:	1 inch
Mast diameter:	2 inches' max
Weight:	3 pounds
Connector:	Type N female
Gain:	16.5 dBi
-3 dB Beamwidth (E Plane):	30°
F/B ratio:	>20 dB
Maximum Power:	550 W. average
Stacking Distance:	
H Plane	21 1/2 in. vertical
E Plane	24 in. horizontal

PARTS LIST

Note: All hardware is Stainless Steel unless otherwise noted.

Quantity	Description	Quantity	Description
2	.058" x 1" Drilled boom	18	4-40 x 1 1/4" Screw
1	Boom to Mast "L" Bracket	18	4-40 Lock nut
2	Reflectors 1 & 2	2	8-32 x 1 3/8" Screw
1	Driven element	2	#8 Hex nut
10	Directors 1-10	2	#8 Split lock washer
5	Directors 11-15	1	Anti-Seize Compound
1	2" U-bolt with nuts & lock washers	2	1" Black End Cap
1	Saddle	1	Assembly Manual
1	Cable assembly w/connector		

Anti-Seize Compound - Apply a small amount of the supplied Anti-Seize Compound to the aluminum joints and to the threads of the U-Bolts to prevent galling.

BEFORE INSTALLING YOUR NEW ANTENNA, PLEASE BE SURE TO READ THE ENCLOSED WARNING PAMPHLET.

CAUTION: *While we strive to remove all burrs from all machined parts, there is always the possibility of sharp edges. We strongly suggest checking the edges and use a fine file, or 400 grit sandpaper, to remove any burrs that may have been left.*

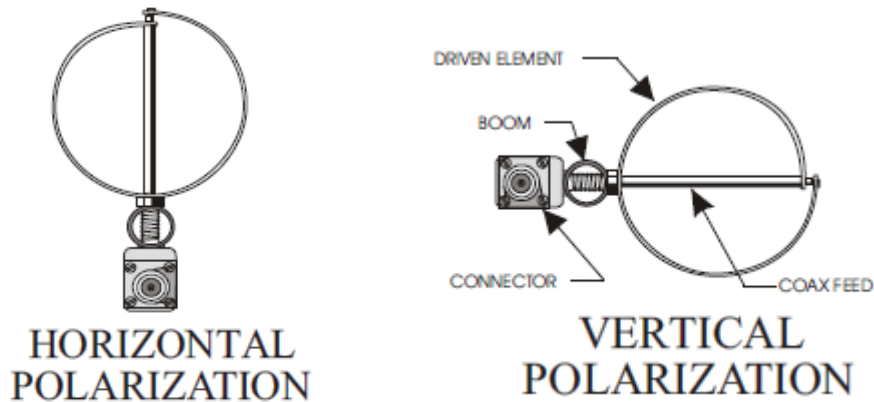

ASSEMBLY INSTRUCTIONS

- 1) Attach loops to the boom with 4-40 x 1 ¼" screws and lock nuts in proper sequence. Loops go on the side of the boom marked with an "X". Attach the contents of each bag of elements before opening the next bag. This will prevent any mix-up of elements on the boom. When tightening the nuts on the parasitic elements, be careful not to torque them too tightly. Snug down the nuts, align the elements and use a screwdriver for the final tightening. A ¼ inch nut driver is almost mandatory for this job! Attach the driven element with the 5/16" nut provided. If only a single antenna is being built, it doesn't matter which way the loop is oriented. If antennas are to be stacked, see "Instructions for Stacking Loop Yagis".
- 2) Attach the boom to mast angle bracket (angle piece) behind the second reflector R2. The bracket can be installed for either horizontal or vertical polarization. Install U-bolt and saddle on the bracket.
- 3) Install the cable assembly through the hole in the driven element mounting bolt. Make sure the connector bracket is correctly oriented, the bend should be forward for center mount antennas and rear facing for rear mount antennas. Solder the outer shield to the driven loop first making sure there is no shield sticking above the large hole in the driven loop. After the shield is soldered, pass the center conductor through the small hole in the driven loop and bend the center conductor over and solder (See Assembly Tips below).

We have created a You Tube video, the link of which can be found on our website, documenting the following steps:

<https://youtu.be/ojXbsDv5cvU>

At this point the connector assembly is facing down, connect a piece of coax and your SWR bridge or VNA. Pull down on the connector (which will flatten the loop) until you reach the lowest SWR. If it's less than 1.5:1 you can stop and make sure the loop doesn't try to pop

back up, sometimes you have to squeeze the loop with your fingers to make sure it stays in the shape that gave the best SWR. If you want to further lower the SWR, from the rear of the antenna, place both your thumbs on the driven loop on either side and gently push it forward towards D1, you only need to tilt it maybe $\frac{3}{16}$ " to $\frac{1}{4}$ " and that should drop the SWR to 1.1:1 or less.

Now, GENTLY bend the UT-141 coax after it exits the boom towards the front or rear, depending on the mounting. You do not want to bend it so tightly that it crushes where it extends through the bolt. The connector bracket should line up with either D1 or D2 (or the hole with the circle around it on rear mount antennas), remove that nut and place the connector bracket on the screw and re-attach the nut. If the bracket doesn't line up, sometimes you have to flip the bracket. Loosen the $\frac{3}{4}$ " nut by holding the connector body with a $\frac{9}{16}$ " open end wrench. Remove the connector bracket and flip it.



Connector doesn't fit



Front Mount Connector



Rear Mount Connector

- 4) Attach the feedline and tape it to the mast. Seal all connections with silicone RTV or equivalent.
- 5) Attach the two black end caps and this will complete the assembly of your DSE3318LYARMK.
- 6) The SWR should be 1.5:1 or better. Additional tweaking can be accomplished by adjusting the distance between the driven element and R1, or by adjusting the shape of the driven element.

DO NOT, UNDER ANY CIRCUMSTANCES, APPLY ANY TYPE OF SEALANT OR COATING TO THE DRIVEN ELEMENT, T-ARMS OR CONNECTOR ASSEMBLY, OTHER THAN KRYLON® CLEAR COAT. ANY OTHER COATING WILL ADVERSELY AFFECT THE SWR AND VOID YOUR WARRANTY.

ASSEMBLY TIPS:

The boom diameter is 1 inch, and it is drilled for 4-40 hardware (no. 33 drill bit). The driven element hole is enlarged to 5/16 inch. All elements are 0.032-inch-thick and 0.375 inch wide. Note that the element spacing from D7 on is 5.115 inches. The loops and driven element are preformed to their proper shape. The connector/coax assembly is soldered to the driven element as shown below. Form the coax cable using your thumb as a guide to bend the coax and bracket so that the bracket mounting hole is aligned at the R1 drilled hole in the boom. (See drawing below.) Be careful with the .141" coax. It can be crimped if not supported by your thumb! Attach the coax bracket with the hardware from R1. For the best match, the driven element should be approximately 4 inches high: this makes it wider than it is tall. This shape can be adjusted for best match. The space between the loop ends should be 3/8" (9.5mm). This spacing will prevent water from "beading up" there during wet weather. The design of this antenna is based on work done by G3JVL.

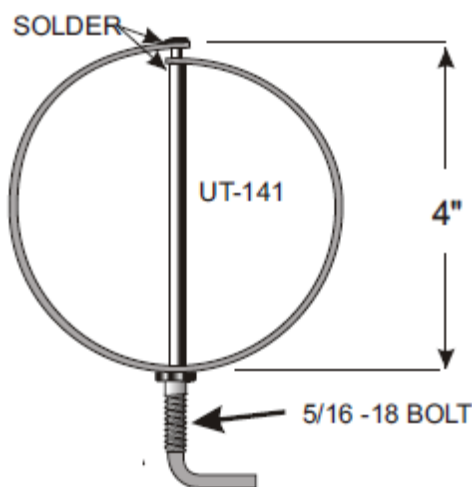

Soldered Driven Element

Directive Systems Warranty Policy

All Directive Systems antennas are built with the finest materials available. We take great pride in building a quality product that will give years of good service and performance. If there is a defect in materials or workmanship within 90 days of purchase, Directive Systems will repair or replace the defective part, free of charge, to the original purchaser. **DO NOT RETURN ANYTHING WITHOUT PRIOR AUTHORIZATION FROM DIRECTIVE SYSTEMS.** Please contact us either by phone or email describing the problem and we will work to resolve it.

If, after examining a new antenna you received, you are not satisfied, contact us immediately for return authorization and refund. **ANY ANTENNA THAT HAS BEEN MODIFIED WILL BE SUBJECT TO A RESTOCKING CHARGE. IF AN ANTENNA IS SO MODIFIED AS TO MAKE IT UNUSABLE, DIRECTIVE SYSTEMS RESERVES THE RIGHT TO REFUSE TO ACCEPT THE ANTENNA FOR RETURN.**

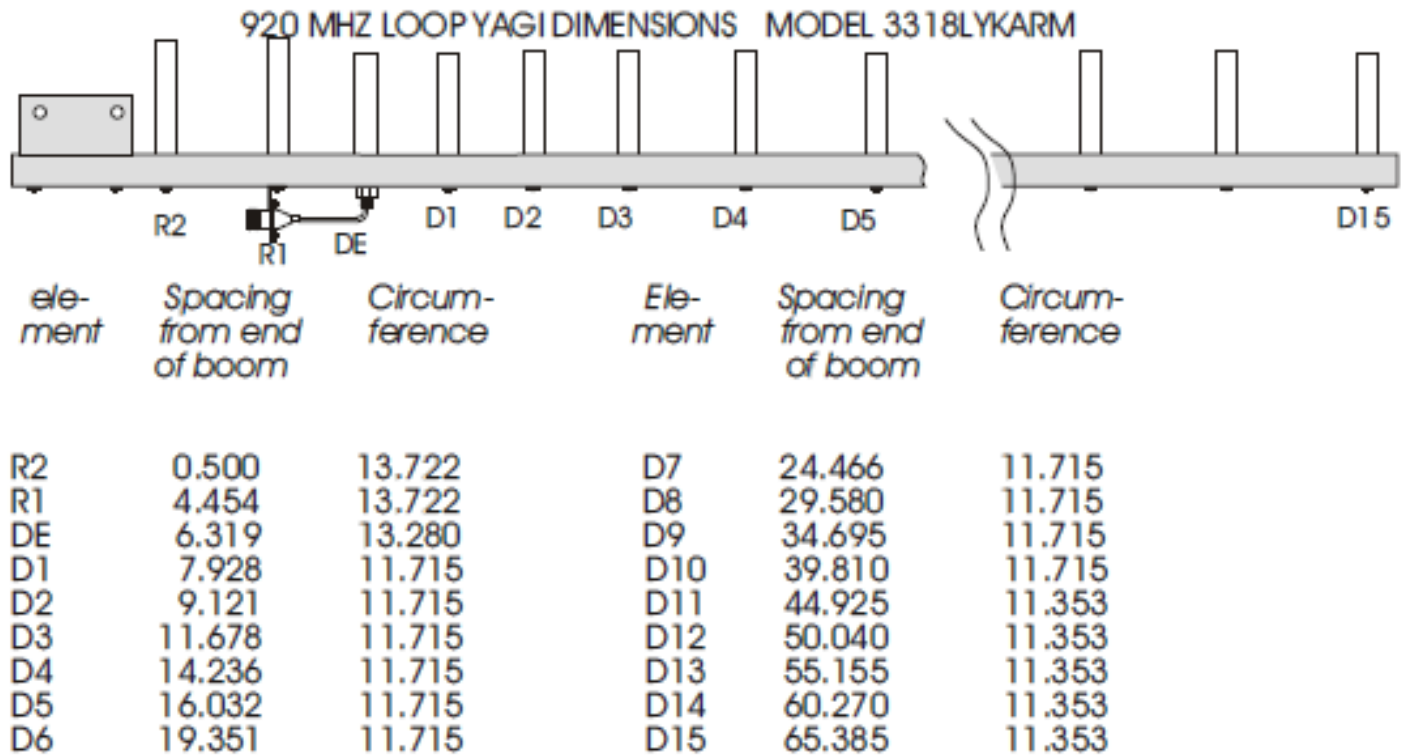

Note: All dimensions are in inches.