

# Directive Systems & Engineering

2702 Rodgers Terrace  
Haymarket, VA 20169-1628

[www.directivesystems.com](http://www.directivesystems.com)

703-754-3876

## 33cm Loop Yagi, Model DSE3347LYAK (w/sub-boom)



### SPECIFICATIONS

Frequency range:	910-928 MHz	Gain:	20.5dBi
Number of elements:	47	3 dB Beamwidth	
Boom length:	216 inches	(E plane):	14.4°
Boom diameter:	1 inch	F/B ratio:	>20 dB
Mast diameter:	2 inches max	Maximum Power:	550 W average
Weight: (assembled)	13 pounds	Stacking distance:	38 inches' vertical
Connector:	Type N female		41 inches' horizontal

### PARTS LIST

*Note: All hardware is Stainless Steel unless otherwise noted.*

Quantity	Description	Quantity	Description
3	.058"x1" Drilled boom sections	47	4-40 x 1 1/4" screw
1	Sub-boom 63" x 3/4" sq. tubing	47	4-40 lock nut
1	Sub-boom 42 1/2" x 3/4" sq. tubing	4	8-32 x 1/2" screw
2	Sub-boom brackets	8	8-32 x 1 1/4" screw
2	Sub-boom plates	4	8-32 x 1 3/8" screw
1	Boom to Mast Bracket	2	8-32 x 2" screw
1	Boom to Mast Plate	18	8-32 hex nut

2	Reflectors 1 & 2	18	#8 Split Lock Washer
1	Driven element	2	2" U-bolt with nuts & lock washers
11	Directors 1-11	2	Saddles
7	Directors 12-18	1	Cable assembly w/connector
6	Directors 19-24	1	Anti-Seize Compound
12	Directors 25-36	2	1" Black End Cap
8	Directors 37-44	1	Assembly Manual

**Anti-Seize Compound** - Apply a small amount of the supplied Anti-Seize Compound to the aluminum joints and to the threads of the U-Bolts to prevent galling.

**BEFORE INSTALLING YOUR NEW ANTENNA, PLEASE BE SURE TO READ THE ENCLOSED WARNING PAMPHLET.**

**CAUTION:** *While we strive to remove all burrs from all machined parts, there is always the possibility of sharp edges. We strongly suggest checking the edges and use a fine file, or 400 grit sandpaper, to remove any burrs that may have been left.*



**HORIZONTAL  
POLARIZATION**

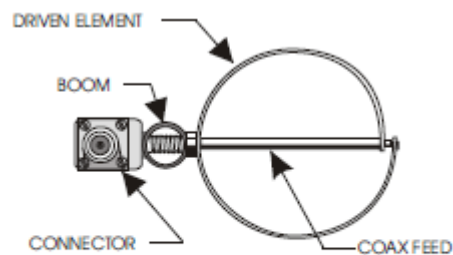

**VERTICAL  
POLARIZATION**

**ASSEMBLY INSTRUCTIONS**

- 1) Slide the three boom sections together, matching the colors at each splice connection. Temporarily secure the booms with a 4-40 x 1 1/4" screw and lock nut at each boom splice.
- 2) Attach loops to the boom with 4-40 x 1 1/4" screws and lock nuts in proper sequence. Loops go on the side of the boom marked with an "X". Attach the contents of each bag of elements before opening the next bag. This will prevent any mix-up of elements on the boom. The boom splice is between D16-17 & D30-31 and is held together with the mounting screws for these elements. When tightening the nuts on the parasitic elements, be careful not to torque them too tightly. Snug down the nuts, align the elements, and use a screwdriver for the final tightening. A 1/4" nut driver is almost mandatory for this job! Attach the driven element with the 5/16" nut provided. If only one antenna is being built, it doesn't matter which way the loop is oriented. If multiple antennas are to be stacked, see "Instructions for Stacking Loop Yagis."

3) Install the cable assembly through the hole in the driven element mounting bolt. Make sure the connector bracket is correctly oriented, the bend should be forward for center mount antennas and rear facing for rear mount antennas. Solder the outer shield to the driven loop first making sure there is no shield sticking above the large hole in the driven loop. After the shield is soldered, pass the center conductor through the small hole in the driven loop and bend the center conductor over and solder (See Assembly Tips below).

*We have created a You Tube video, the link of which can be found on our website, documenting the following steps:*

<https://youtu.be/ojXbsDv5cvU>

At this point the connector assembly is facing down, connect a piece of coax and your SWR bridge or VNA. Pull down on the connector (which will flatten the loop) until you reach the lowest SWR. If it's less than 1.5:1 you can stop and make sure the loop doesn't try to pop back up, sometimes you have to squeeze the loop with your fingers to make sure it stays in the shape that gave the best SWR. If you want to further lower the SWR, from the rear of the antenna, place both your thumbs on the driven loop on either side and gently push it forward towards D1, you only need to tilt it maybe 3/16" to 1/4" and that should drop the SWR to 1.1:1 or less.

Now, GENTLY bend the UT-141 coax after it exits the boom towards the front or rear, depending on the mounting. You do not want to bend it so tightly that it crushes where it extends through the bolt. The connector bracket should line up with either D1 or D2 (or the hole with the circle around it on rear mount antennas), remove that nut and place the connector bracket on the screw and re-attach the nut. If the bracket doesn't line up, sometimes you have to flip the bracket. Loosen the 3/4" nut by holding the connector body with a 9/16" open end wrench. Remove the connector bracket and flip it.



Connector doesn't fit



Front Mount Connector



Rear Mount Connector

Refer to photos on the next few steps for clarification.

4) Install the 3/4" square tubing boom to mast bracket at D21 using 8-32 x 2" screws, nuts and lock washers (See Photo 1). Insert the screws through the boom then through the bracket. Attach the boom to mast plate to this bracket using 8-32 x 1 1/4" screws nuts and lock washers.

5) Install the  $\frac{1}{2}$ " aluminum angle sub-boom brackets at D13 and D33 using 8-32 x  $1 \frac{3}{8}$ " screws, nuts and lock washers (See Photo 2). Insert the screws through the boom then through the bracket. Attach the sub boom plates to each bracket using 8-32 x  $\frac{1}{2}$ " screws, nuts and lock washers. Once again, insert the screws through the sub boom plates, then through the bracket.

6) The shorter  $\frac{3}{4}$ " square tubing sub boom already has the splice installed and locked in place by an 8-32 x  $1 \frac{1}{4}$ " screw (See Photo 1). Slide the second  $\frac{3}{4}$ " sub boom onto the splice until the hole and the alignment marks line up. Now remove the 8-32 x  $1 \frac{1}{4}$ " screw from the sub boom. Mount the sub boom to the two sub boom plates and the main boom to mast plate using the 8-32 X  $1 \frac{1}{4}$ " screws, nuts and lock washers. It is best to just finger tighten the hardware on the sub boom until everything is together. Note: There may be extra holes in the sub boom for boom sag adjustment.



Photo 1: Boom to Mast Bracket and Plate





Photo 2: Sub Boom Bracket and Plate

- 7) Support the antenna on a support mast with the 2" U-bolts and adjust the main boom until the sag is minimized. Tighten the hardware to lock the sub boom plates in place. There should be hardly any sag in the boom when this is accomplished.
- 8) Attach the feedline and tape it to the bottom of the boom. Seal all coax connections with butyl rubber, silicone RTV or equivalent.



- 9) Attach the two black end caps, and this will complete the assembly of your DSE3347LYAK.
- 10) The SWR should be 1.5:1 or better. Additional tweaking can be accomplished by adjusting the distance between the driven element and R1 or by adjusting the shape of the driven element.

**DO NOT, UNDER ANY CIRCUMSTANCES, APPLY ANY TYPE OF SEALANT OR COATING TO THE DRIVEN ELEMENT, T-ARMS OR CONNECTOR ASSEMBLY, OTHER THAN KRYLON® CLEAR COAT. ANY OTHER COATING WILL ADVERSELY AFFECT THE SWR AND VOID YOUR WARRANTY.**

### ASSEMBLY TIPS:

The boom diameter is 1 inch, and it is drilled for 4-40 hardware (no. 33 drill bit). The driven element hole is enlarged to 5/16 inch. All elements are 0.032-inch-thick and 0.375 inch wide. Note that the element spacing from D7 on is 5.115 inches. The feed coaxial cable (0.141-inch semi rigid) goes through the mounting bolt and is soldered to the open ends of the element. For best match, the driven element should be approximately 4 inches high; this makes it wider than it is tall. This shape can be adjusted for best match. This antenna is based on work done by G3JVL.

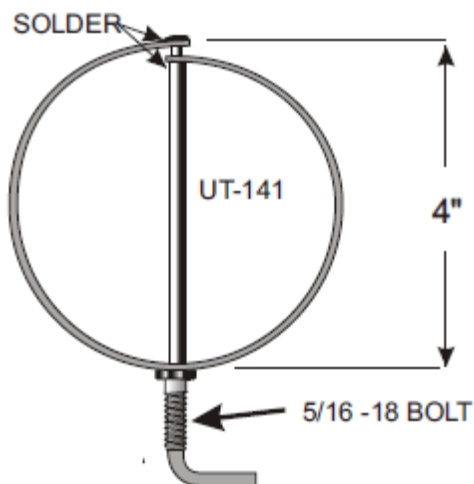

Soldered Driven Element

