

# Directive Systems & Engineering

2702 Rodgers Terrace  
Haymarket, VA 20169-1628

[www.directivesystems.com](http://www.directivesystems.com)

703-754-3876

## 915 MHz Loop Yagi, Model DSE3333LYAK

### SPECIFICATIONS

Frequency range:	910-930 MHz	Gain:	18.5 dBi
Number of elements:	33	3 dB Beamwidth	
Boom length:	144 inches	(E plane):	20°
Boom diameter:	1 inch	F/B ratio:	>20 dB
Mast diameter:	1 1/2 inches max	Maximum Power:	550 W average
Weight: (assembled)	5 pounds	Stacking distance:	30 inches vertical
Connector:	Type-N female		33 inches horizontal

### PARTS LIST

Quantity	Description	Quantity	Description
2 pcs	drilled boom	1 pkg	4-40 stainless steel screws, nuts, lock washers, 8-32 hardware
2	reflectors 1&2		
1	driven element		
11	directors 1-11	1	boom to mast bracket
7	directors 12-18	1	boom to mast plate
12	directors 19-30	1	U-bolt with nuts & saddle
		1	Cable assembly with connector

### ASSEMBLY INSTRUCTIONS

- 1) Attach loops to the boom with 4-40 screws, nuts and lock washers in proper sequence. Loops go on the side of the boom marked with an "x" or "top". The boom is spliced between D16 and D17 and is held together with the mounting screws for these elements. When tightening the nuts on the parasitic elements, be careful not to torque them too tightly. Snug down the nuts, align the elements, and use a screwdriver for the final tightening. A 1/4" nut driver is almost mandatory for this job! Attach the driven element with the 5/16-18 nut provided. If only one antenna is being built, it doesn't matter which way the loop is oriented. If antennas are to be stacked, see "Instructions for Stacking Loop Yagis."
- 2) Attach the boom-to-mast plate and bracket (square tubing piece). The mounting center is D15. Install U-bolts so that the mast comes up directly under the boom.
- 3) Install the cable assembly through the hole in the driven element mounting bolt and solder the ends to the ends of the loop. Solder the inner conductor first. Bend the connector

forward and secure it to the boom with the bracket provided. (The bracket is secured by the nut for D1.) Attach the feedline and tape it to the bottom of the boom. Seal all connections with silicone RTV or equivalent.

4) The SWR should be 1.5:1 or better. Additional tweaking can be accomplished by adjusting the distance between the driven element and R1 or by adjusting the shape of the driven element.

#### ASSEMBLY TIPS:

The boom diameter is 1 inch, and it is drilled for 4-40 hardware (no. 33 drill bit). The driven element hole is enlarged to 5/16 inch. All elements are 0.032 inch thick and 0.375 inch wide. Note that the element spacing from D7 on is 5.115 inches. To bend elements, wrap the strip around a suitable form (such as a piece of pipe or tubing). The driven element is formed in the same way then soldered to the mounting bolt as shown. The feed coaxial cable (0.141 inch semi rigid) goes through the mounting bolt and is soldered to the open ends of the element. For best match, the driven element should be approximately 4 inches high; this makes it wider than it is tall. This shape can be adjusted for best match. This antenna is based on work done by G3JVL.

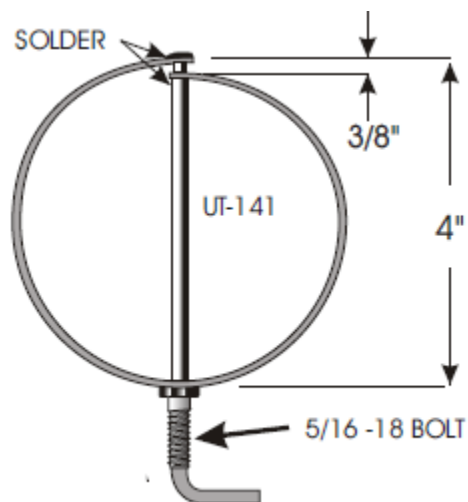

## DIMENSIONS OF 910-930 MHz LOOP YAGI, MODEL 3333LYAK

Element	Spacing from end of boom	Circumference	Element	Spacing from end of boom	Circumference	Element	Spacing from end of boom	Circumference
R2	0.500	13.722	D9	34.695	11.715	D20	90.960	10.927
R1	4.954	13.722	D10	39.810	11.715	D21	96.075	10.927
DE	6.319	13.280	D11	44.925	11.715	D22	101.190	10.927
D1	7.928	11.715	D12	50.040	11.353	D23	106.305	10.927
D2	9.121	11.715	D13	55.155	11.353	D24	111.420	10.927
D3	11.678	11.715	D14	60.270	11.353	D25	116.535	10.927
D4	14.236	11.715	D15	65.385	11.353	D26	121.650	10.927
D5	16.032	11.715	D16	70.500	11.353	D27	126.765	10.927
D6	19.351	11.715	D17	75.615	11.353	D28	131.880	10.927
D7	24.466	11.715	D18	80.730	11.353	D29	136.995	10.927
D8	29.580	11.715	D19	85.845	10.927	D30	142.110	10.927

Note: All dimensions are in inches.

### Directive Systems Warranty Policy

All Directive Systems antennas are built with the finest materials available. We take great pride in building a quality product that will give years of good service and performance. If there is a defect in materials or workmanship within 90 days of purchase, Directive Systems will repair or replace, free of charge, the defective part. **DO NOT RETURN ANYTHING WITHOUT PRIOR AUTHORIZATION FROM DIRECTIVE SYSTEMS.** Please contact us either by phone or email describing the problem and we will work to resolve it. If, after examining a new antenna you received, you are not satisfied, contact us immediately for return authorization and refund. **ANY ANTENNA THAT HAS BEEN MODIFIED WILL BE SUBJECT TO A RESTOCKING CHARGE. IF AN ANTENNA IS SO MODIFIED AS TO MAKE IT UNUSABLE, DIRECTIVE SYSTEMS RESERVES THE RIGHT TO REFUSE TO ACCEPT THE ANTENNA FOR RETURN.**